



ISOMETER[®] isoCHA425HV

with AGH420-1/AGH421-1



ISOMETER® isoCHA425HV with AGH420-1/AGH421-1

The ISOMETER® isoCHA425HV in combination with the AGH420-1/AGH421-1 coupling device monitors the insulation resistance for DC fast charging stations according to the CHAdeMO standard or according to the Combined Charging System (CCS) for nominal system voltage ranges between DC 0 V and 1000 V.

- Switchable between CCS (Combined Charging System) and CHAdeMO
- Nominal voltages up to DC 1000 V
- Detection of symmetrical and asymmetrical insulation faults
- Electrically isolated Modbus RTU interface
- Display of the fault location (DC-balanced)

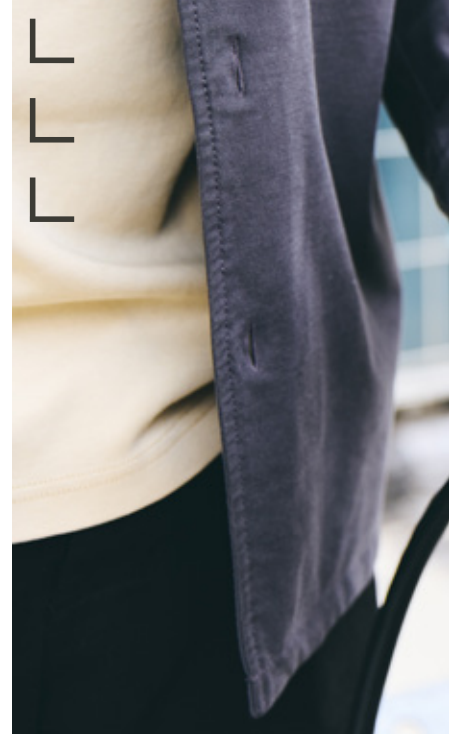

Benefits:

- Only one device for use in all regions and applications
- Compact design for optimum utilisation of the available installation space
- High system reliability and availability of the charging station thanks to patented measuring method
- Cost-optimised installation thanks to reduced wiring effort and a wide range of communication interfaces

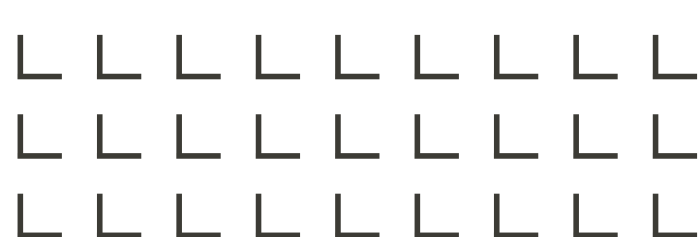



Benefits:

- Can be used worldwide thanks to international approvals
- Optimised and accelerated testing and approval processes for UL-certified charging stations
- High flexibility and low variant diversity thanks to switching between CHAdeMO and CCS mode
- Reliable and future-proof



ISOMETER® isoCHA425HV
with AGH420-1

Standards

A high level of electrical safety is a priority for DC charging stations. In order to minimise the risk to the user, the ISOMETER® isoCHA425HV fulfils all the important requirements placed on the insulation monitoring device by the standards and regulations.

- IEC 61851-23:2023 ED2
- UL 2231-1 / -2
- EN 61557-8
- CCS1 (US) / CCS2 (Eur)
- CHAdeMO



CHAdeMO

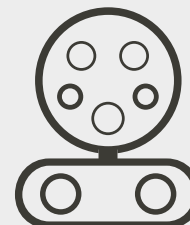

CCS1



CCS2

Measurement technology

Patented and reliable measuring methods ensure a high degree of safety and high availability of the DC charging station

- Detection of insulation faults up to 2 M Ω
- Maximum allowed system leakage capacitance of 20 μ F – **Unique in the market**
- Active measuring method can detect symmetrical and asymmetrical insulation faults
- Voltage measurement with overvoltage and undervoltage detection
- Automatic device self-test with connection monitoring

Benefits:

- High system reliability
- High availability of the charging station
- Ideal for e-bus charging applications etc. thanks to high permissible leakage capacitance

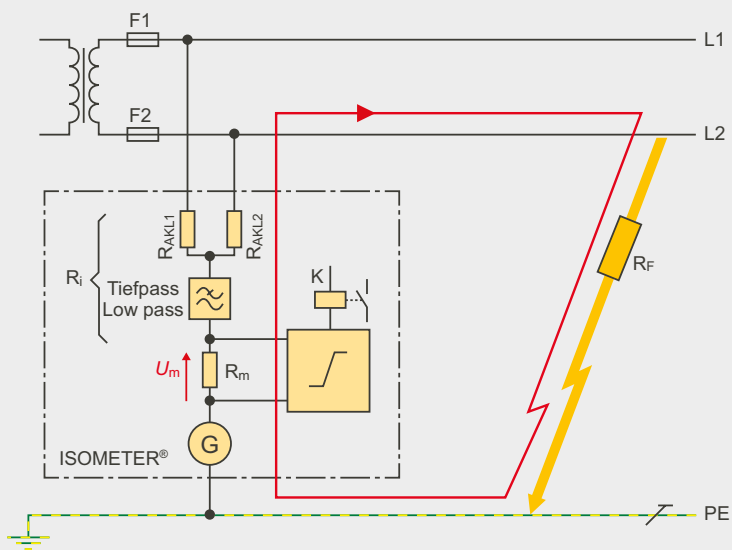

Operating principle ISOMETER®



Form factor and connections

The demand for elegant and compact fast charging stations is on the rise. The ISOMETER® isoCHA425HV supports this trend with its compact design.

- Most compact design in the market:
 - Coupling device AGH420-1/AGH421-1: 36 mm x 93 mm (W x H)
 - ISOMETER® isoCHA425HV: 36 mm x 93 mm (W x H)
- Flexible arrangement of insulation monitoring and coupling device
- Push-In wire connectors

Benefits:

- Optimum utilisation of the available installation space within the charging station
- Time savings during production thanks to fast wiring

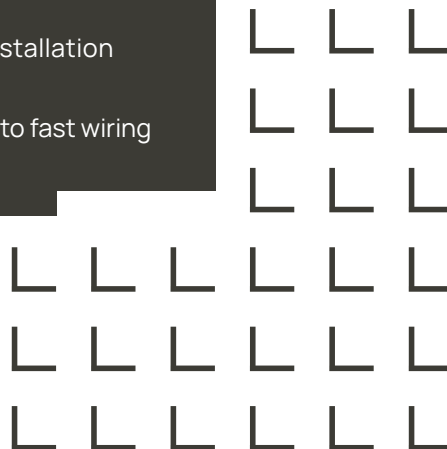



"With the isoCHA insulation monitor from Bender, our charging systems are safe and fulfil the current charging standards. With its high, permissible system leakage capacitances, it makes it possible to charge large electric vehicles."

Dr. Raoul Heyne,
ADS-TEC Energy, Senior Expert Charging



Interfaces and communication

- RS-485
- Modbus RTU
- IsoData
- LC display
- Password protection against unauthorised parameter changes

Benefits:

- Quick and easy integration of the IMD in the charge controller using standard protocols
- Simple troubleshooting on site by means of the RC display

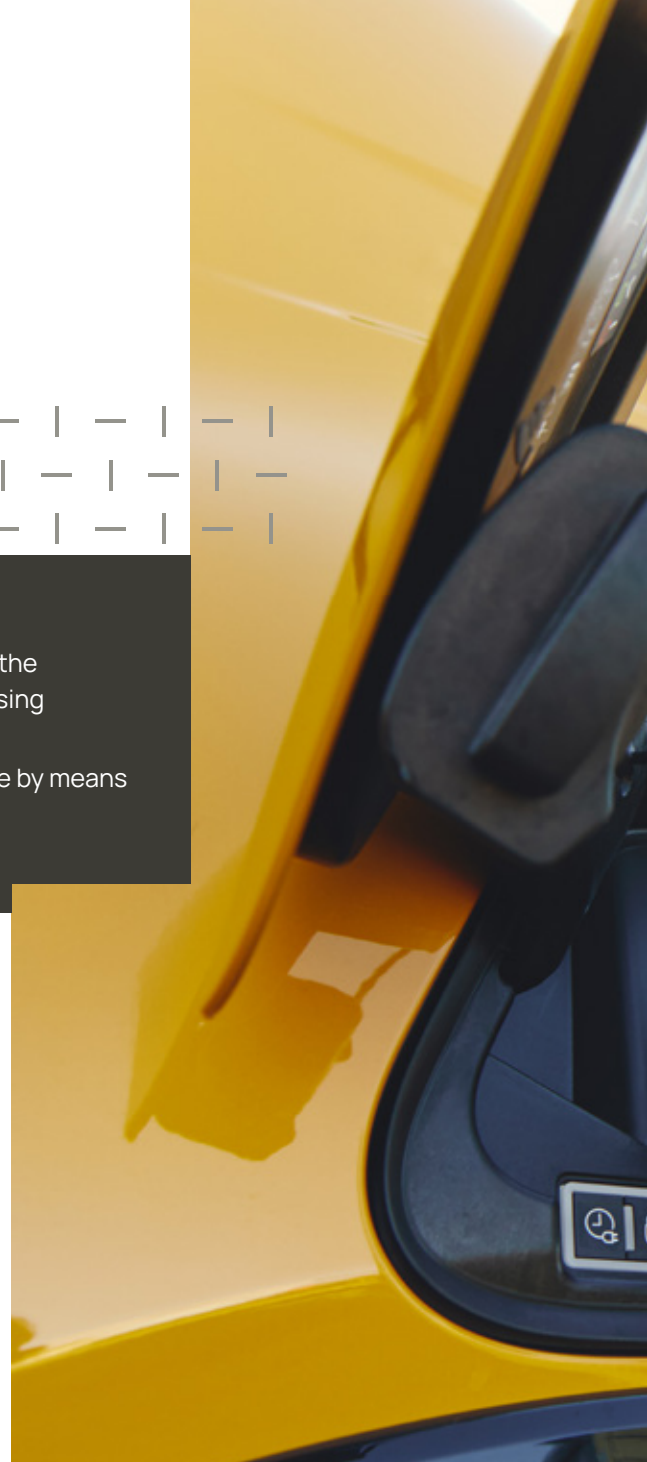
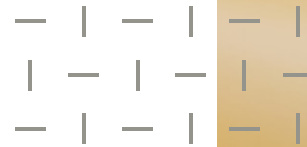



Coupling device AGH421-1

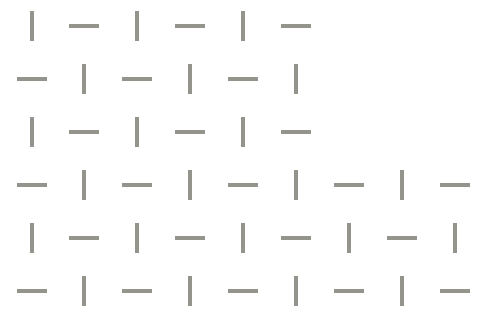

In fast charging stations with dynamic load distribution to two charging points, one IMD often has to be disconnected from the grid to avoid interference as long as the maximum power of a charging station is only made available to one vehicle.

The new AGH421-1 coupling device in combination with the ISOMETER® isoCHA425HV enables disconnection from the grid without the installation of additional switching units.

Benefits:

- Cost and space savings within the charging station by eliminating additional switching units
- Reduced wiring effort during the production process

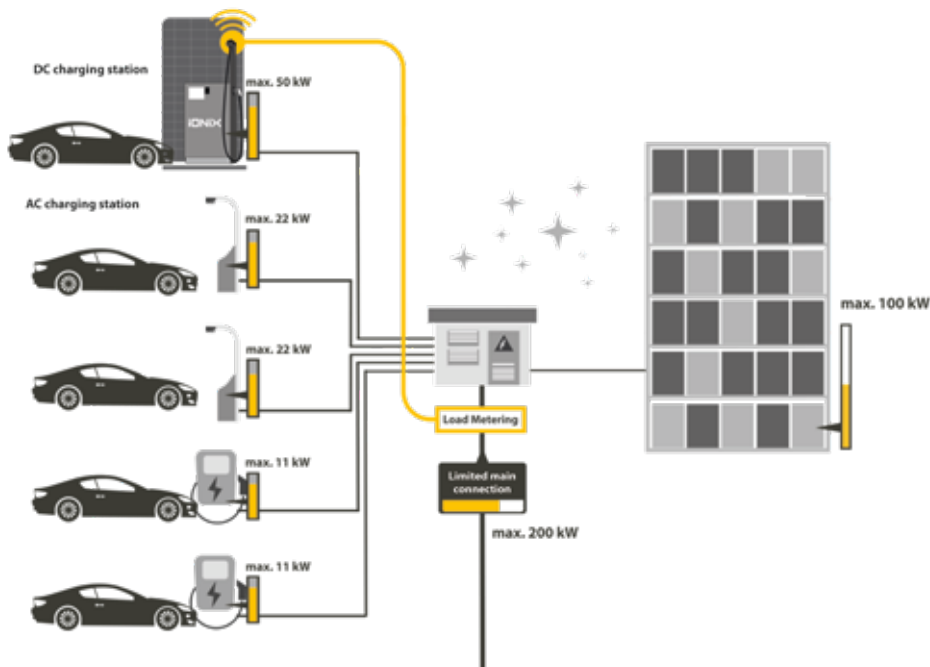

Both IMDs are active

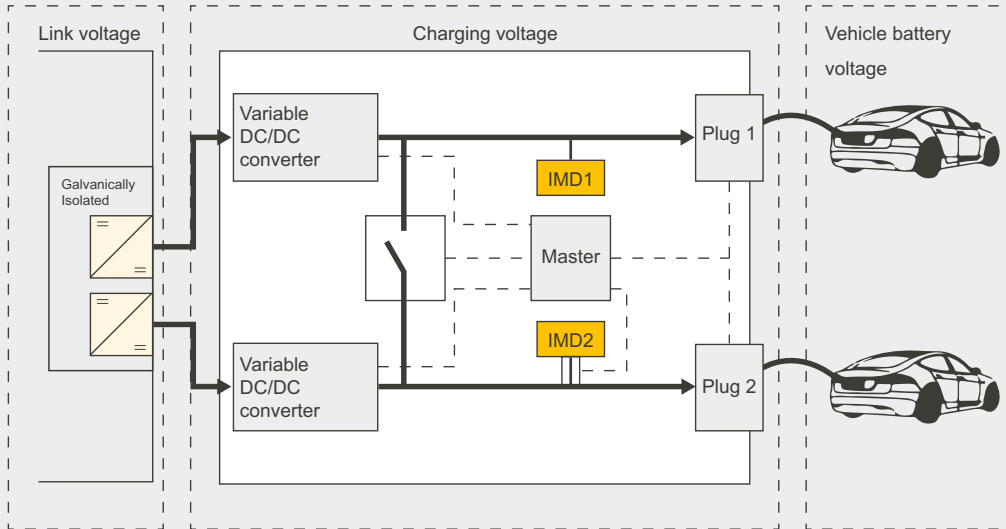

IMD 2 disconnected from the system to be monitored

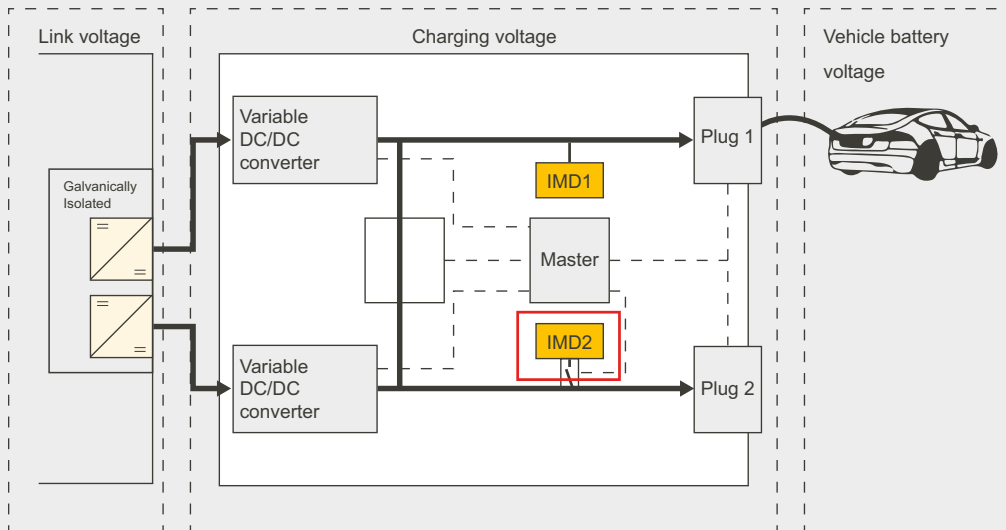

The entire available power is used for charging one vehicle. IMD2 must be disconnected to avoid interference

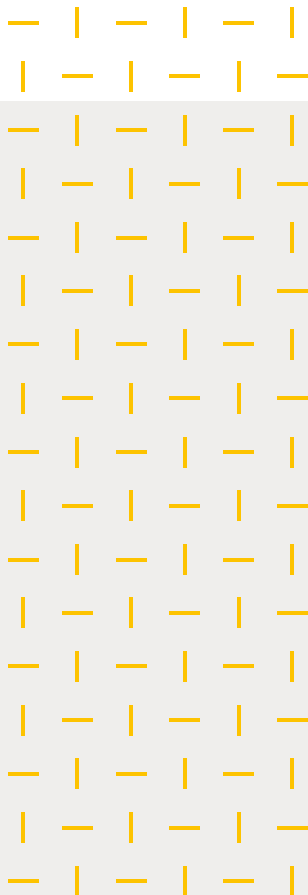

Bender GmbH & Co. KG

Londorfer Straße 65
35305 Grünberg
Germany

Tel.: +49 6401 807-707
emobility@bender.de
www.bender.de/en

Fotos: Adobe Stock (© Southworks, © BornHappy)
and Bender Archive.

2248en / 05.2024 / © Bender GmbH & Co. KG,
Germany – subject to change! The specified standards
take into account the version valid at the time of
printing.

